

users guide

Mexico Super

Your Ideal users guide

See reverse for **Mexico Super** installation & servicing instructions

CF445, CF455, CF465 & CF475

When replacing a part on this appliance use only spare parts that you can be assured conform to the safety and performance specification that we require. Do not use reconditioned or copy parts that have not been clearly authorised by Ideal Boilers.

i BOILERS
Ideal
ENGINEERED FOR PEACE OF MIND

MEXICO SUPER (NATURAL GAS MODELS ONLY)

Mexico Super	CF445	G.C. No. 41 392 81
Mexico Super	CF455	G.C. No. 41 392 82
Mexico Super	CF465	G.C. No. 41 392 83
Mexico Super	CF475	G.C. No. 41 392 84

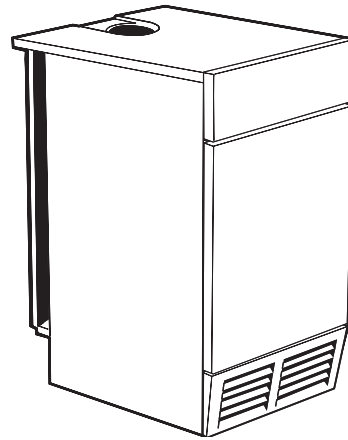

Certified - P.I. No. CF 87 AT 15

Destination Countries: GB, IE

INTRODUCTION

It is essential that the instructions in this booklet are strictly followed, for safe and economical operation of the boiler.

Current Gas Safety (Installation & Use) Regulations or rules in force.

In your own interest, and that of safety, it is the law that this boiler must be installed by a CORGI registered installer or in IE a competent person, in accordance with the above regulations.

Electricity Supply

This appliance must be efficiently earthed.

Supply: 230 V ~ 50 Hz.

The fusing should be 3A.

Connection must be made in a way that allows complete isolation of the electrical supply such as a double pole switch having a 3mm (1/8") contact separation in both poles, or a plug and socket, serving only the boiler and system controls. The means of isolation must be accessible to the user after installation.

Important Points

- If the boiler is installed in a compartment then the compartment MUST NOT be used for storage purposes.*
- The ventilation provided for the boiler during installation MUST NOT be blocked, and a check should be made periodically that the ventilation areas are free from any obstruction.*
- If it is known or suspected that a fault exists on the boiler then it MUST NOT be used until the fault has been corrected by a CORGI registered installer or in IE a competent person.*

- Inflammable materials must not be placed in close proximity to the appliance. Materials giving off flammable vapours must not be stored in the same room as the appliance.*
- Under NO circumstances should any of the sealed components on this appliance be used incorrectly or tampered with.*

TTB Downdraught Thermostat (CF boilers only)

This appliance is fitted with a TTB downdraught thermostat for added safety and protection. If this thermostat should operate and switch off the appliance it is because the flue is subject to downdraught, probably as a result of adverse wind conditions.

The TTB is an automatic reset thermostat which will reset once wind conditions have returned to normal, subject to a built-in reset delay in excess of 10 minutes.

The TTB is an IMPORTANT SAFETY DEVICE and MUST NOT be put out of action or interfered with in any way.

The TTB is not a substitute for an independently mounted carbon monoxide detector.

In cases of repeated or continuous shutdown a CORGI registered person or in IE a competent person should be called to investigate and rectify the condition causing this and carry out an operational test after each intervention on the device. Only the manufacturer's original parts should be used for replacement.

Minimum Clearances

A clearance of 533mm (21") MUST be available at the front of the boiler for servicing.

The minimum clearances given in Table 1 MUST be complied with, in order to maintain the safe running of the boiler.

CAUTION. To avoid the possibility of injury during the installation, servicing or cleaning of this appliance care should be taken when handling edges of sheet steel components

1 BOILER CLEARANCES

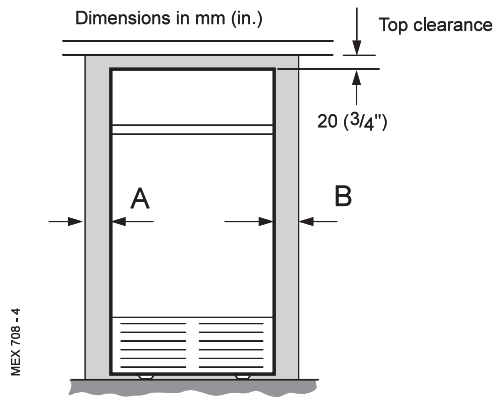

Table 1

Boiler	Minimum A or B mm (ins.)	Minimum A + B mm (ins.)
CF445, CF455, CF465	10 (3/8)	110 (4 1/2)
CF475	55 (2 1/4)	110 (4 1/2)

2 BOILER CONTROLS

LEGEND

- A. Gas control valve.
- B. Burner pressure test point.
- C. Main burner pressure adjuster.
- D. Inlet pressure test point.
- E. Gas service cock.
- F. Sightglass.
- G. Boiler thermostat knob.
- H. Main burner 'On' neon.
- J. Overheat thermostat reset button (optional).

Note.

Grille assembly not shown, for clarity

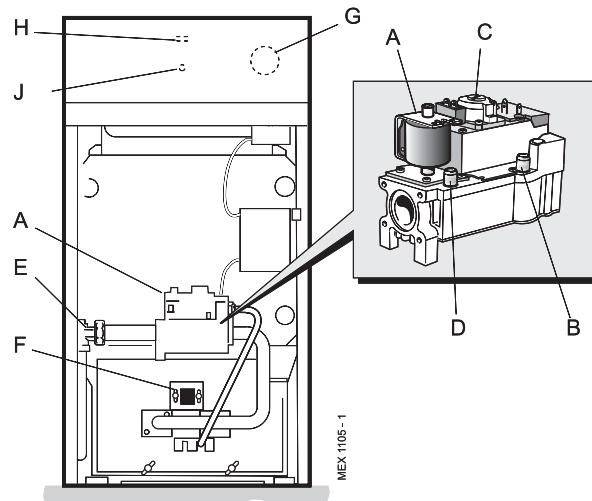

To Light the Boiler. Refer to Frame 2

If a programmer is fitted refer to separate instructions for the programmer before continuing.

1. Check that the electricity supply to the boiler is OFF.
2. Open the control panel drop-down door and ensure that the thermostat knob (G) is in the OFF position.
3. Switch ON the electricity supply to the boiler and check that all external controls, e.g. room thermostat etc., are ON.
4. Set the boiler thermostat knob (G) to position 6. The pilot solenoid valve should open and the intermittent spark commence, continuing until the pilot is established. The main burner will then cross-light smoothly.

Winter conditions (i.e. central heating and domestic hot water). The thermostat should be positioned at setting 5 or 6.

Summer conditions (i.e. domestic hot water only). The thermostat should be positioned at setting 2.

These settings are offered for general guidance only and other settings may be found preferable, dependent upon the type of system installed or as recommended by the installer.

To Shut Down the Boiler

1. For short periods

Turn the boiler thermostat knob (G) to OFF. When heating is again required, restore the knob to its original setting.

2. For longer periods

- a. Turn the boiler thermostat knob (G) to OFF.
- b. Switch the electricity supply to OFF.

All CORGI registered installers carry a CORGI ID card, and have a registration number. Both should be recorded in your **Benchmark** Log Book. You can check your installer by calling CORGI direct on 01563 72300

Caradon Ideal Limited is a member of the Benchmark initiative and fully supports the aims of the programme. Benchmark has been introduced to improve the standards of installation and commissioning of central heating systems in the UK and to encourage the regular servicing of all central heating systems to ensure safety and efficiency.



THE LOG BOOK SHOULD BE COMPLETED AFTER EACH SERVICE AND KEPT WITH THESE INSTRUCTIONS

POINTS FOR THE BOILER USER

Note. In line with our current warranty policy we would ask that you check through the following guide to identify any problems external to the boiler prior to requesting a service engineers visit. Should the problem be found to be other than with the appliance we reserve the right to levy a charge for the visit, or for any pre-arranged visit where access is not gained by the engineer.

TROUBLESHOOTING - TYPICAL NON PRODUCT FAULTS

Problem	Solution
Boiler is not working for central heating or hot water.	<ul style="list-style-type: none"> • Check boiler thermostat (G) is turned up. • Check the overheat thermostat reset button (J) by holding button in for 2 seconds and then releasing. • If fitted to a sealed system check the pressure gauge on the system, this should read a minimum of 1 bar. If necessary re-pressurise the system via the filling loop. Press the overheat thermostat reset button (J). If the boiler still does not fire or if the pressure continues to drop after refilling contact the installer. • Has there previously been a smell of fumes from the flue ? It is likely that the downdraught thermostat has operated due to the combustion gases not being evacuated from the flue. Contact your installer to check the flue is operating correctly and not blocked etc.
Boiler goes through ignition sequence but fails to light in either mode.	<ul style="list-style-type: none"> • Check gas supply (try at another gas appliance cooker/fire etc) If no gas supply then this is not a boiler fault – contact your gas supplier.
Boiler is operating satisfactorily for domestic hot water but will not operate for central heating.	<ul style="list-style-type: none"> • If an external programmer is fitted check that the central heating channel is at an 'on' period. • Check that the room thermostat is set at the required temperature. Test the room thermostat by turning this fully up – if this does not respond contact your installer.
Boiler is operating satisfactorily for central heating but will not operate for domestic hot water.	<ul style="list-style-type: none"> • If an external programmer is fitted check that the domestic hot water channel is at an 'on' period. • Check that the domestic hot water cylinder thermostat is set at the required temperature. Test the cylinder thermostat by turning this fully up – if this does not respond contact your installer.
Boiler will not fire the pilot light is lit but the igniter continues to spark and the main burner does not ignite.	<ul style="list-style-type: none"> • This is a symptom of crossed polarity i.e. the live and neutral supply to the boiler are crossed over. This is not a boiler fault contact your installer to correct the wiring.